

SED2 Variable Frequency Drives Conventional Bypass (C-Bypass) Options



Description

The Bypass Options are companion packages for the family of SED2 Variable Frequency Drives.

For information on the family of SED2 VFDs, see the *SED2 Variable Frequency Drives Submittal Sheet* (154-042).



Bypass Power Features

- 2-Contactor: Output & Bypass
 - Overload protection in bypass mode.
 - Step-down transformer with fused primary and secondary.
 - Contactors electrically and mechanically interlocked.
- 3-Contactor (optional): Input, Output, & Bypass
In addition to the 2-contactor features, 3-Contactor features provide:
 - Drive test function
 - Complete electrical isolation of drive
- Input Device
 - Disconnect
 - Fused disconnect (optional)
 - Circuit breaker (optional)
 - All doors are interlocked and padlockable
- Reactor Options
 - Line reactor mounted in bypass option enclosure.
 - Line reactor (in NEMA 1 enclosure) supplied separately.
 - Load reactor mounted in bypass option enclosure.
 - Load reactor (in NEMA 1 enclosure) supplied separately.

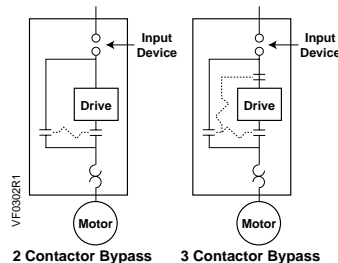

Bypass Control Features

- Auto Bypass
 - Relay logic allows user to send the motor to bypass mode based on the drive's programmable relay.
 - The drive's programmable relay, typically set to fault, can be set up for applications that run full speed for an extended period of time.
- Enable Input
 - Generally used for safety tie-ins; the motor will not operate the drive or bypass when open.
- Common Remote Start/Stop
 - Common remote start/stop can be used in both drive and bypass mode.
- Essential Services Mode
 - Typically used for smoke purge; the motor goes to bypass regardless of the selected mode.
 - No call to stop will have an effect, including open safety or stop commands.
 - Only turning the power off or opening this contact will stop the motor.

Bypass – Door Mounted Control Devices

- 2-Contactor Units
 - Drive-Off-Bypass selector
 - Bypass pilot light
- 3-Contactor Units
 - Drive-Off-Bypass selector
 - Bypass pilot light
 - Drive Test on/off selector

Product Numbers

Your Product Number:																				
Example Product Number:		V	B	A	4	4	0	.	D	1	2	0	X							
Model																				
	VB	VFD with Bypass																		
	VV	VFD Variant [See Note 1]																		
	BY	Bypass only [See Note 1]																		
Series																				
	A	Conventional Bypass																		
Voltage																				
	1	208 V																		
	2	230 to 240 V																		
	3	380 to 480 V																		
	4	500 to 600 V																		
HP rating																				
0.5, 0.7,		[See Note 2 for these selections]																		
1.0, 1.5, 2.0, 3.0, 4.0, 5.0, 7.5,																				
10., 15., 20., 25., 30., 40., 50., 60.,																				
75., 100, 125		[See Note 3 for these selections]																		
Disconnect																				
	D	Disconnect																		
	F	Fused Disconnect																		
	B	Circuit Breaker																		
NEMA rating																				
	1	NEMA Type 1																		
	5	NEMA Type 12 [See Note 4]																		
Contactor																				
	0	None																		
	2	2 Contactors																		
	3	3 Contactors																		
Reactor		[See Note 5]																		
	0	None																		
	3	Line Reactor																		
	5	5% Line Reactor																		
	L	Load Reactor																		
Filter																				
	X	Factory Required Designator																		
	A	Filtered to Class A requirements																		
Options		(If no option is required, leave field blank)																		
	(3-digit No.)	Standard Variant Number (3-digit factory-assigned number)																		
	HA1	High Amp Rating [See Note 6]																		
	("M" plus 2 alpha char.)	Multiple Motor Control ("M" plus 2 factory-assigned alpha char.)																		
	CMS	Contactor Motor Selection																		

Notes:

1. VV and BY models are not available in all combinations.
2. Available only with Voltage Codes 1, 2, and 3.
3. Available only with Voltage Codes 3 and 4.
4. Available only in certain VBA/VVA models.
5. Only a single reactor can be installed in a bypass enclosure.
If both are required, a separate enclosed reactor is required.
6. HA1 option is a bypass rated to 178 amps at 480 Vac.
It is only available as 125 hp, 480V.
Though it does not meet NEC for 150 hp at 180 amps, the package will be able to control a high percentage of 150 hp motors.

Typical Specifications

SED2 Bypass Options shall send the motor to bypass mode based on an easily accessible door-mounted selector or based on the drive's programmable relay. A bypass pilot light shall provide indication of the bypass mode. The bypass mode shall provide overload protection. Contactors shall be electrically and mechanically interlocked. An essential services mode shall send the motor to bypass regardless of the selected mode.

Dimensions

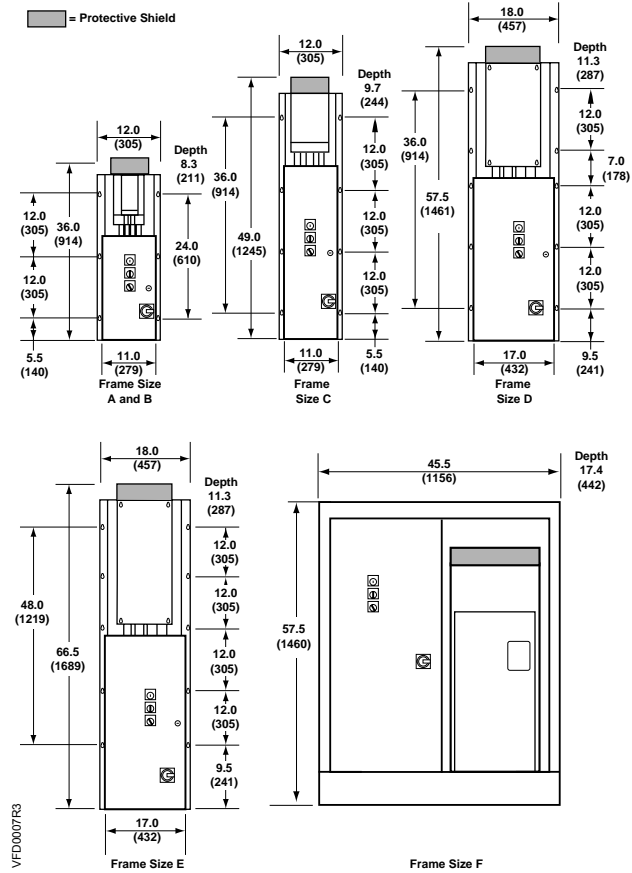

Figure 1. C-Bypass Dimensions in Inches (cm).

Table 1. C-Bypass Approximate Weights.

Frame	Wt. lb (kg)
A	55 (25)
B	65 (29)
C	100 (45)
D	170 (77)
E	200 (91)
F	500 (227)

NOTE: Exact weight will be affected by actual horsepower/voltage and selected power options.

Table 2. C-Bypass Frame Sizes and Power Ranges.

HP	kW	208/240V	480V	575V
.5	.37			
.75	.55	A		
1	.75		A	
1.5	1.1	B		
2	1.5		B	
3	2.2			C
5	4	C		
7.5	5.5		C	
10	7.5			
15	11	D		
20	15			
25	18.5	E	D	D
30	22			
40	30	F	E	E
50	37			
60	45			
75	55		F	F
100	75	N/A		
125	90			
HA1	-			N/A

Table 3. C-Bypass Output Current Ratings (Amps) — Per NEC Motor Tables.

HP	.5	.75	1	1.5	2	3	5	7.5	10	15	20	25	30	40	50	60	75	100	125	HA1
208V	2.3	3.0	3.9	5.5	7.4	10.4	16.7	22	28	42	54	68	80	104	130	154	-	-	-	-
240V	2.2	3.0	3.9	5.5	6.8	9.6	15.2	22	28	42	54	68	80	104	130	154	-	-	-	-
480V	1.1	1.6	2.1	3.0	3.4	4.8	7.6	11	14	21	27	34	40	52	65	77	96	124	156	178
575V	.9	1.3	1.4	2.1	2.7	3.9	6.1	9	11	17	22	27	32	41	52	62	77	99	125	-

NOTE: Drives are current rated devices. Verify that the listed ratings are ≥ the motor full load current rating.

Wiring Diagrams

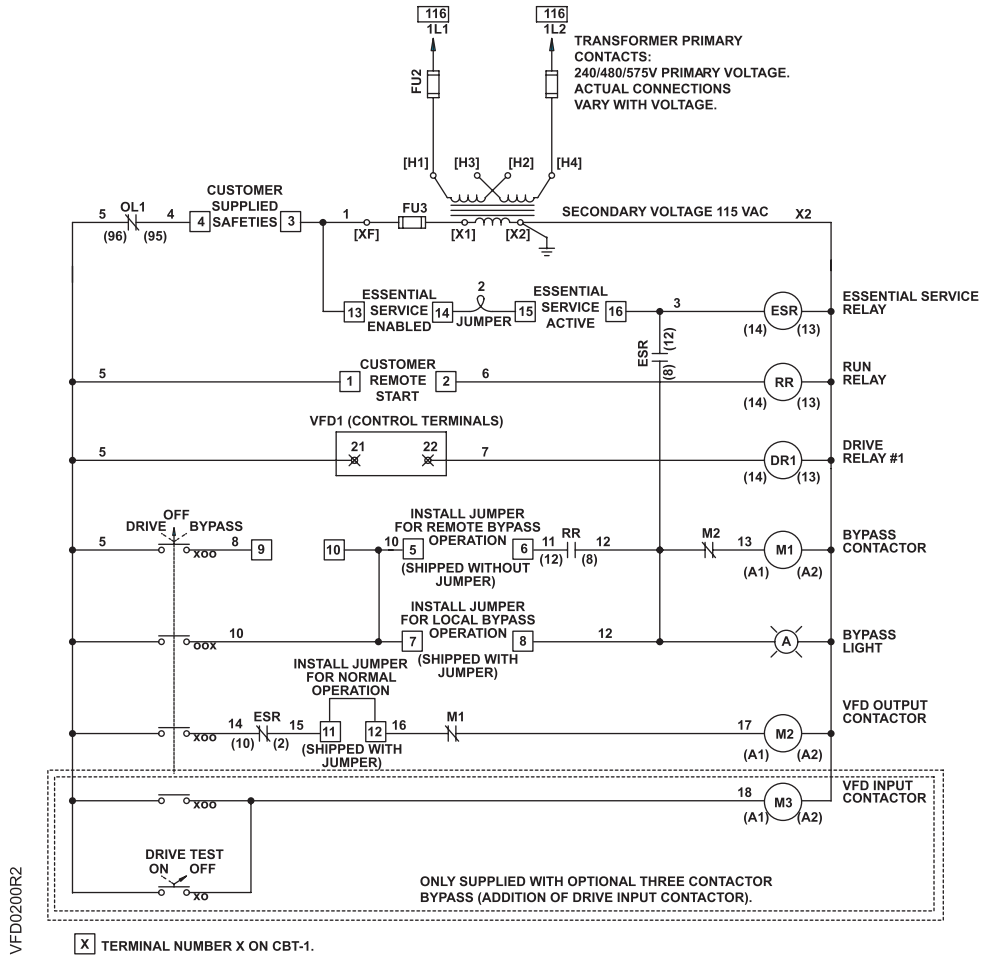
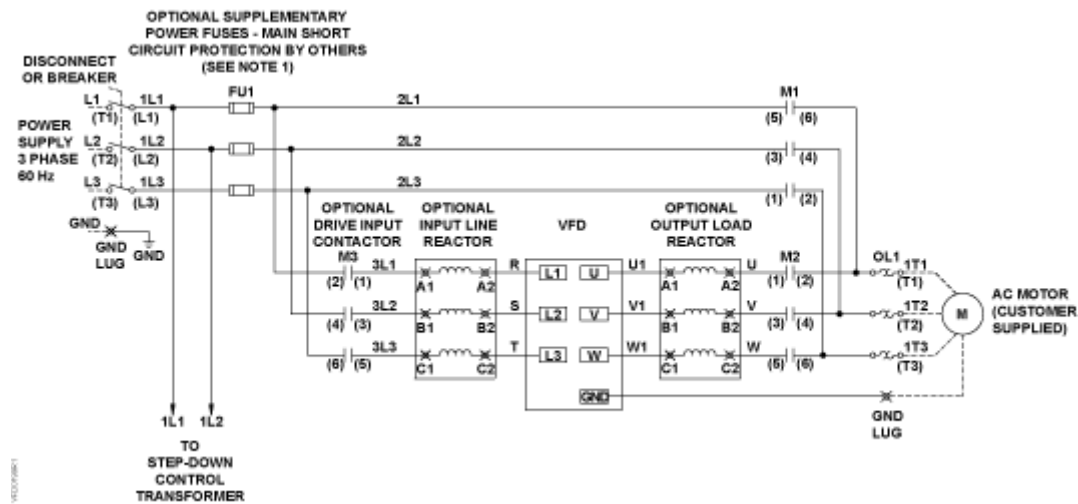

Figure 2. C-Bypass 120 Vac Control Circuit.

Wiring Diagrams continued



NOTES:

1. Branch circuit protection to be provided by installer, per UL508A, if not provided with drive.
2. For bypass operation, modify these drive parameters: P0704[0] and P0704[1] = 3.
3. Control and communication wiring should be 300V UL minimum.
4. Communication wiring should be run with maximum separation possible from all other wiring.
5. Essential service mode operates the motor full speed (bypass) with no protection for the motor or system.
6. Ensure that automatic bypass will not damage the system before activating.
7. See Siemens Publication No. 125-3215 for proper fuse and wire sizes.
8. See Siemens Publication No. 125-3201 for SED2 VFD input/output control signal wiring details.

Figure 3. C-Bypass Power Circuit.

Wiring Diagrams continued

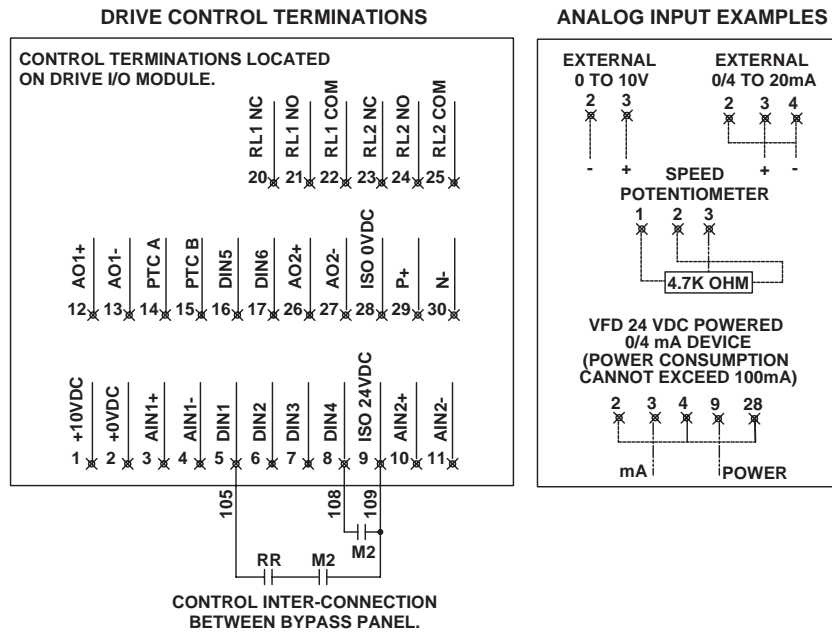

BYPASS CONTROL TERMINATIONS

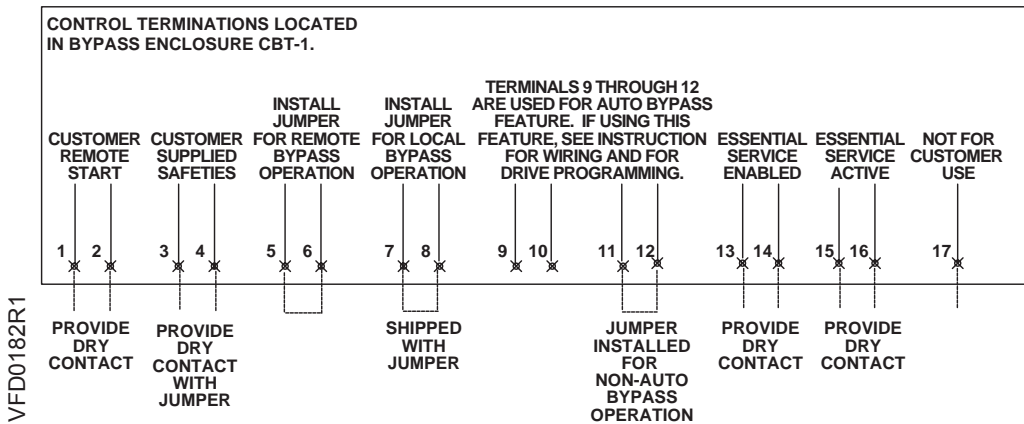

Figure 4. C-Bypass Terminations.

Table 4. C-Bypass Specifications.

Specifications	Description
Input Voltage (3 phase)	208V, 3AC ±10%
	240V, 3AC ±10%
	480V, 3AC ±10%
	575V, 3 AC ±10%
Temperature	Operating: 32°F to 104°F (0°C to 40°C)
	Storage: -40°F to 158°F (-40°C to 70°C)
Humidity	0 to 95% rh, non-condensing

Table 5. Drive Specifications.

Drive Specifications	Description
Input voltage and power ranges (3-phase)	208V and 230V to 240V, 3AC $\pm 10\%$. 1/2 hp to 60 hp
	380V to 480V, 3 AC $\pm 10\%$ 1/2 hp to 125 hp
	500V to 600V, 3 AC $\pm 10\%$ 1 hp to 125 hp
Input frequency	47 Hz to 63 Hz
Output frequency	0 Hz to 150 Hz
Power factor	≥ 0.9 total, ≥ 0.97 displacement
VFD degree of efficiency	96% to 97%
Switch-on current	Less than nominal input current
Auxiliary supply 24V	Galvanically separated, unregulated auxiliary supply (18V to 32V) 100 mA
Overload capacity	110% for 60 seconds
Control method	Linear, parabolic and programmable V/f; and flux current control low-power mode
PWM frequency	2k Hz to 16k Hz (adjustable in 2k Hz increments)
Fixed frequencies	15 programmable
Skip frequency bands	4 programmable
Setpoint resolution	0.01 Hz digital, 0.01 Hz serial, 10 bit analog
Digital inputs (sink/source)	6: fully programmable and scalable isolated digital inputs, switchable
Analog inputs	2: 0 to 10 Vdc, 0/4 to 20 mA, can also be configured as digital inputs or Ni 1000 input
Relay outputs	2: configurable 30 Vdc /5A (resistive), 250 Vac 2A (inductive)
Analog outputs	2: programmable (0/4 to 20 mA or 0 Vdc to 10 Vdc)
Serial interface	RS-485; Protocols: USS, P1 and N2; Transmission rate: Up to 38.4k Baud
Protection level	IP20: NEMA Type 1 with protective shield and gland plate installed
	IP54: NEMA Type 12
Temperature ranges	Operating: 14°F to 104°F (–10°C to 40°C)
	Storage: –40°F to 158°F (–40°C to 70°C)
Humidity	95% rh, non-condensing
Operational altitudes	Up to 3280 ft (1000m) above sea level without derating
Protection features	Under-voltage, Over-voltage, Overload, Ground fault, Short circuit, Stall prevention, Locked motor, Motor overtemperature I ² t PTC, Over-temperature, Parameter PIN protection.
Standards	UL, cUL, CE, C-tick
CE conformity	Conformity with EC Low Voltage Directive 73/23/EEC

NOTE: SED2 Compliance with EN61000-3-12:
Beginning September 1, 2005 all electrical apparatus covered by the EMC directive must comply with EN61000-3-12 "Limits for harmonic currents produced by equipment connected to public low voltage systems with input currents > 16A and ≤ 75 A per phase".

Siemens variable speed drives of the product range SED2 (Micromaster 436) fulfill the requirements of the EN 61000-3-12 (without the need for external line reactors) regarding the THD values of Table 3 under the pre condition of $R_{sc} > 190$. The required PWhd values will not be achieved. Due to this fact it is recommended to apply for connection approval at the local electricity board.

The local electricity board will evaluate among many other data the content of the 5th harmonic current and the Line Power Factor "Lambda", which is the ratio of active power and apparent power.

Siemens frequency inverters are optimized in design and operation characteristics regarding energy efficiency and less interference with line supplies.

