

See Page No.	152	153	154	155	156	157	158	159	159	159	161	162
BELIMO ACTUATOR	S1, S2 Auxiliary Switch	P... Feedback Potentiometer	SGA24, SGF24 Positioners	PTA-250 Pulse Width Modulation Interface	IRM-100 Input Rescaling Module	ADS-100 Analog to Digital Switch	NSV24 Battery Back-up Module	ZG-R01 Resistor For 4 to 20 mA Conversion	ZG-R02 50% Voltage Divider	ZG-R03, ZG-R05, ZG-R06 Resistor Kits <small>(For multiple actuators with Honeywell Series 90 controllers.)</small>	ZG-X40 Transformer	ZG-HTR Thermostat/Heater Kit
LM24 (-S) US							●				●	
LM24-SR US			●	●	●	●	●	●	●		●	
LM24-MFT US			●			●	●	●	●		●	●
NM24 US							●				●	
NM24-SR US			●	●	●	●	●	●	●		●	
NM24-MFT US			●			●	●	●	●		●	
AM24 (-S) US							●				●	
AM24-SR US			●	●	●	●	●	●	●		●	
AM24-MFT US			●			●	●	●	●		●	
GM24 US	●	●					●				●	
GM24-SR US	●	●	●	●	●	●	●	●	●		●	
GM-24-MFT US	●	●	●			●	●	●	●		●	
LF24 (-S) US											●	●
LF24-SR (-S) US			●	●	●	●	●	●	●		●	●
LF24-3 (-S) US											●	●
LF24-MFT US			●			●	●	●	●		●	●
NF24 (-S) US											●	●
NF24-SR US			●	●	●	●		●	●		●	●
NF120 (-S) US												●
NF24-MFT US			●			●	●	●	●		●	●
AF24 (-S) US											●	●
AF24-SR (-S) US			●	●	●	●		●	●		●	●
AF24-MFT US			●			●	●	●	●		●	●
AF24-MFT95 US										●	●	●
AF120 (-S) US												●
AF230 (-S) US												●

A CLOSER LOOK...

We'll help solve any application problem with a wide range of accessories and unparalleled customer service.

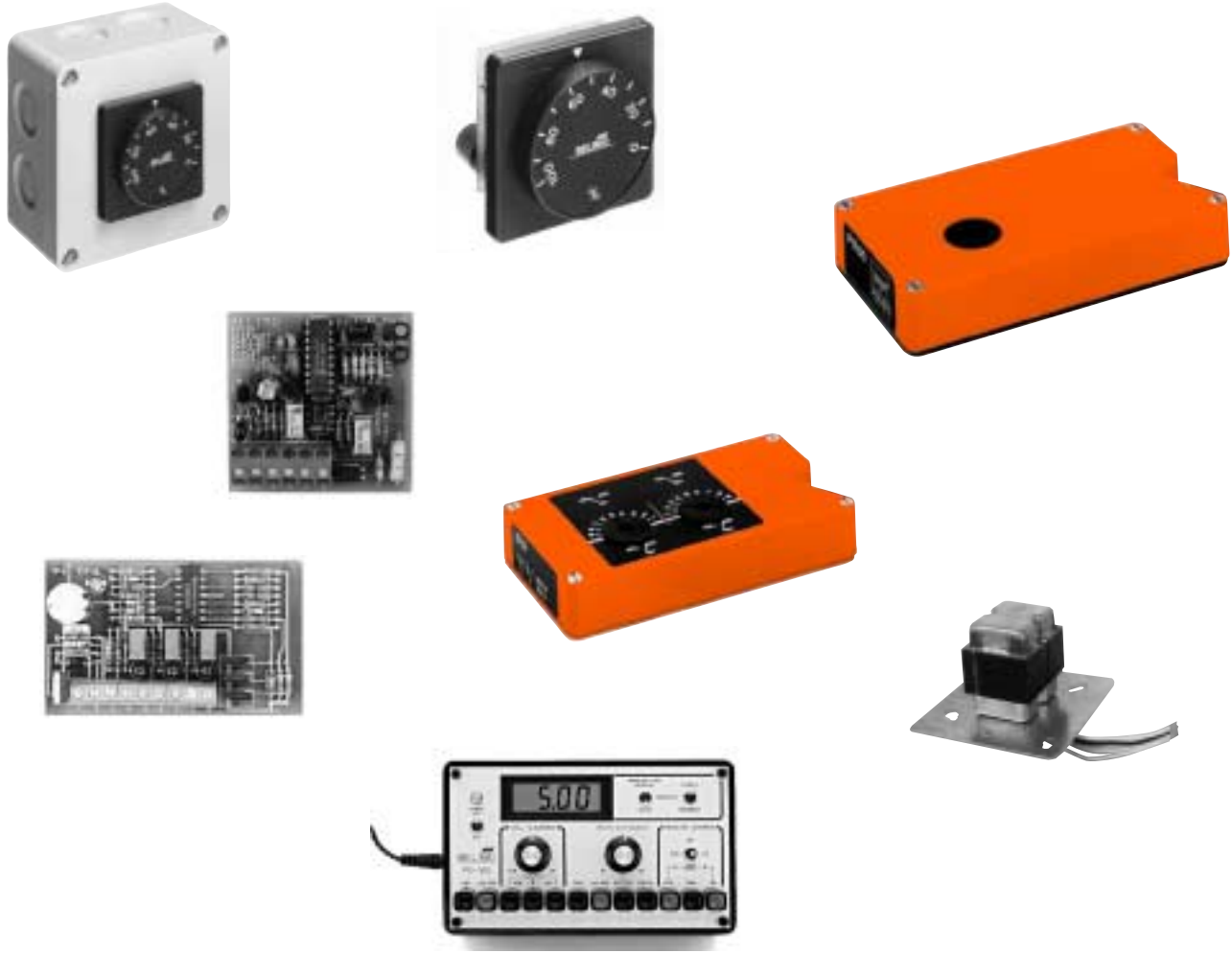

F20358 / 5 4 3 2 1 -01/04-10M-IG-Subject to change. © Belimo Aircontrols (USA), Inc.

The Belimo Difference

- **Customer Commitment.**
Extensive product range. Competitive project pricing. Application assistance. Same-day shipments. Free technical support. Five year warranty.
- **Low Installation and Life-Cycle Cost.**
Easy installation. Accuracy and repeatability. Low power consumption. No maintenance.
- **Long Service Life.**
Components tested before assembly. Every product tested before shipment. 20+ years direct coupled actuator design.

S1, S2 Auxiliary Switches

For the direct coupled actuator SM2.../ GM2...



Wiring diagram

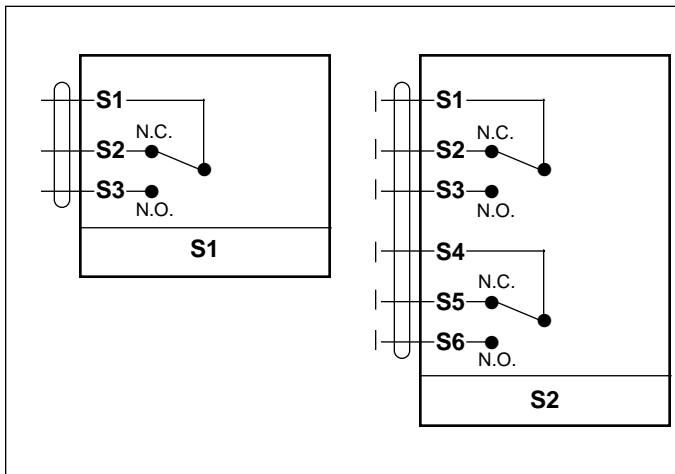

Technical Data	S1	S2
Number of switches	1 SPDT	2 SPDT
Switching capacity	7A (2.5 A) 250 VAC	
Switching point	adjustable over full actuator rotation 0 to 10. Pre-setting with scale possible. Set switching points lockable.	
Electrical connection	3 ft, 18 GA appliance cable	
Humidity	5 to 95% RH non-condensing	
Ambient temperature	-22°F to +122°F [-30°C to +50°C]	
Storage temperature	-40°F to +176°F [-40°C to +80°C]	
Housing	NEMA type 2	
Housing rating	UL94V-0 (flammability rating)	
Servicing	maintenance free	
Agency listings	CE	
Quality standard	ISO 9001	
Weight	5.3 oz [150 g]	7.4 oz [210 g]

Application

The S1 and S2 auxiliary switches are used to indicate when a desired position of a damper is reached or to interface additional controls for a specific control sequence.

Operation

The S1 and S2 auxiliary switches are mounted onto the direct coupled actuator. A spindle transmits the rotary motion of the actuator positively to the switching segments. Any switching point on the micro-switches over the full scale of 0 to 10 can be selected by means of the slotted disc, which can be locked by the fixing screw in the hub of the disc. The position of the switch can be read at any time.

If required, the S1 and S2 can also be mounted on a P... feedback potentiometer, but 2 auxiliary switch units cannot be mounted on top of each other.

Assembly

Use the 4 long bolts, where a S1, S2 auxiliary switch is mounted on top of a P... potentiometer.

Switch setting

1. Turn actuator by hand to the 0 setting.
2. Loosen fixing screw in the center of the slotted disc.
3. Select the desired switching point on the scale marked 0 to 10 by rotating the slotted disc.
4. Re-lock the fixing screws.
5. Check the switching points by turning the actuator by hand. The slotted disc follows rotation. The micro-switches operate when the arrow passed the positions 0 or 10 (white line). The switching symbols indicate the actual switching positions.

Note: with the S1, S2 auxiliary switches, the reversible indicator cannot be used. Use the 4 long bolts when the S1, S2 auxiliary switches are used with the SM24-SR US or GM24-SR US.

Voltage	Resistive	Inductive
120	7 A	5.0 A
250	7 A	2.5 A

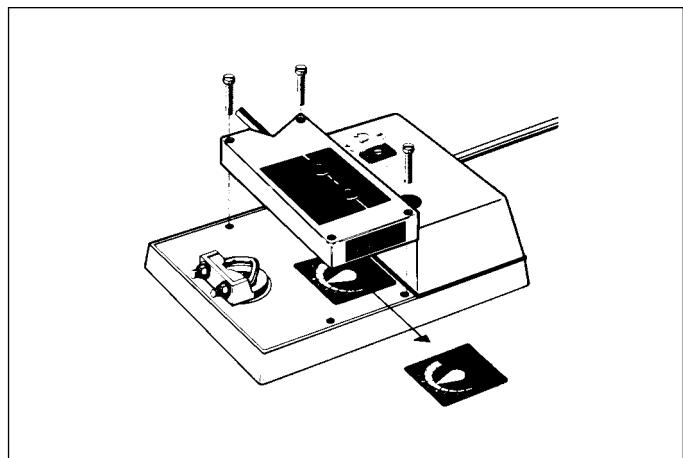



Wiring diagram

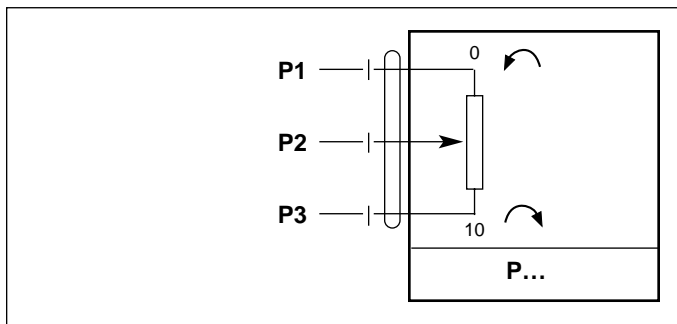

Application

The P... feedback potentiometers are used for continuous damper control in conjunction with normal commercial P-controllers with feedback signals. The P... units can also be used in conjunction with moving coil instruments for position indication, or they can serve as a positioner for parallel operating actuators when used with normal commercial controllers.

Operation

The P... feedback potentiometer is mounted onto the damper actuators. A spindle transmits the rotary motion of the motor positively to the potentiometer, and no adjustments whatsoever are necessary. If required, 2 potentiometer units P... can be mounted on top of each other.

Assembly

Use the 4 long bolts, where 2 P... units are mounted on top of each other.

Types

P500	Feedback potentiometer	500Ω
P1000	Feedback potentiometer	1000Ω
P2800	Feedback potentiometer	2800Ω

Technical Data P...

Resistance values	as above
Output	1W
Tolerance	± 5%
Linearity	± 2%
Resolution	min. 1%
Residual resistance	max. 5% on both sides
Electrical connection	3 ft, 18 GA appliance cable 1/2" conduit connector
Humidity	5 to 95% RH non-condensing
Ambient temperature	-22°F to +122°F [-30°C to +50°C]
Storage temperature	-40°F to +176°F [-40°C to +80°C]
Housing	NEMA type 2
Housing rating	UL94V-0 (flammability rating)
Servicing	maintenance free
Quality standard	ISO 9001
Weight	5.3 oz [150 g]

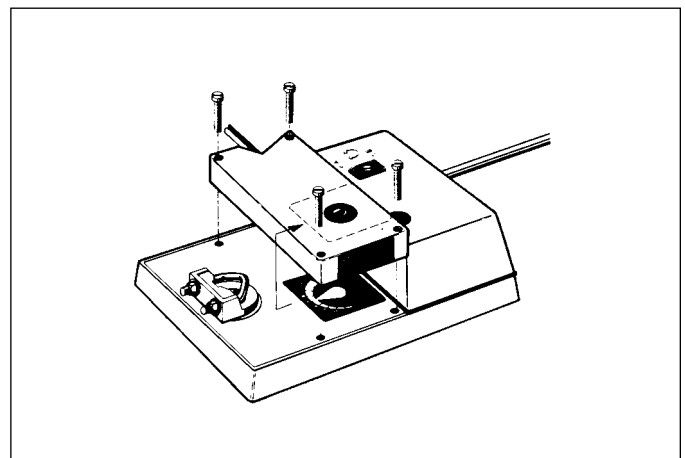

SGA24, SGF24 Positioners



For proportional actuators with a working range of 0 to 10 VDC or 2 to 10 VDC



SGA24



SGF24

Wiring diagram

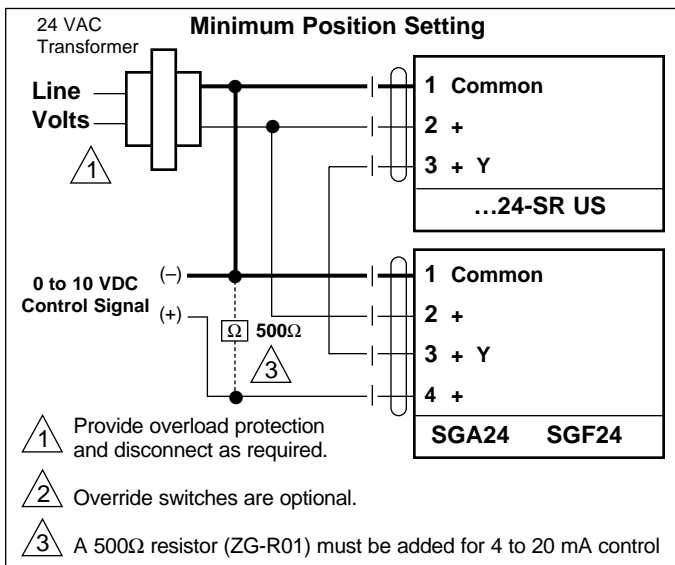
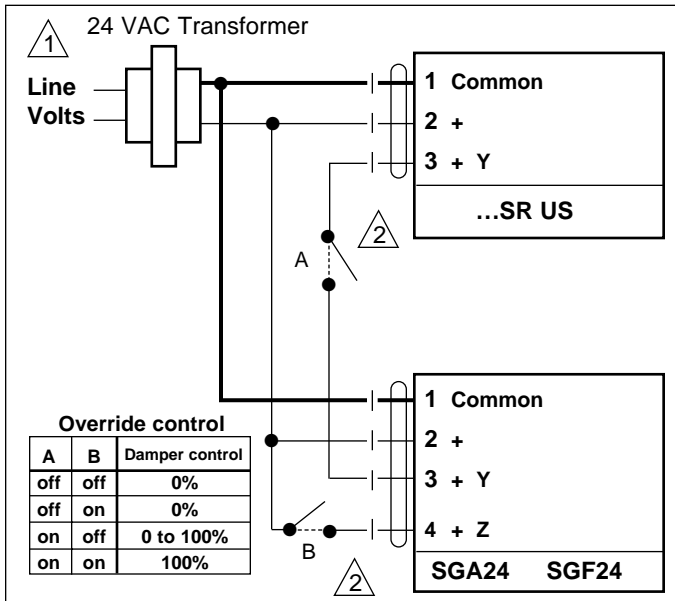

Technical Data	SGA24, SGF24
Power supply	24 VAC ± 20% 50/60 Hz 24 VDC ± 10%
Transformer sizing	1 VA
Control signal Y	.5 to 10 VDC; 2 to 10 VDC (switchable)
Power output	up to 10 actuators (1 mA max)
Degree of protection	(SGA24 only NEMA 4 [1P54])
Connection	Terminals (14 ga. wire max)
Humidity	5 to 95% RH non-condensing

Application

These positioners are intended for the remote control of modulating actuators or for use as a minimum positioner (providing a minimum limit for the output signal from a modulating controller). The control range is 0 to 100% of the angle of rotation of the actuator.

Positioner SGA24 is for surface mounting with a NEMA 4 housing included. Positioner SGF24 is for flush mounting.

Operation

The positioner receives its supply voltage through terminals 1 and 2. A rotary knob is turned, producing a proportional control signal (Y) at the output (terminal 3) of either .5 to 10 VDC or 2 to 10 VDC and therefore a proportional change in the position of the actuator between 0 and 100%. When used for a minimum limit, the positioner works as a higher of 2 signal selector. This function allows only the signal from the controller or positioner, whichever is greater, to go to the actuator.

Function

The changeover from 2 to 10 V to 0 to 10 V is selected by means of a slide switch on the printed circuit board. The angle of rotation of the knob can be limited mechanically, by moving the adjustable stops under the knob.

Accessory

ZG-SGF Mounting plate for single gang wiring box

Changeover switch

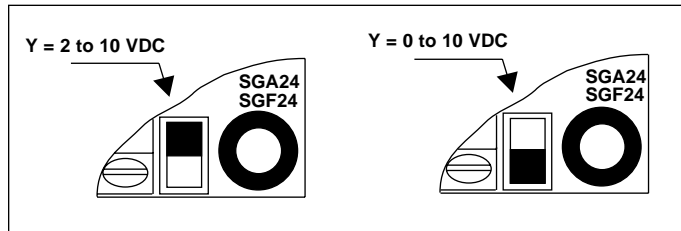

Drilling template for SGF24 (flush mount)

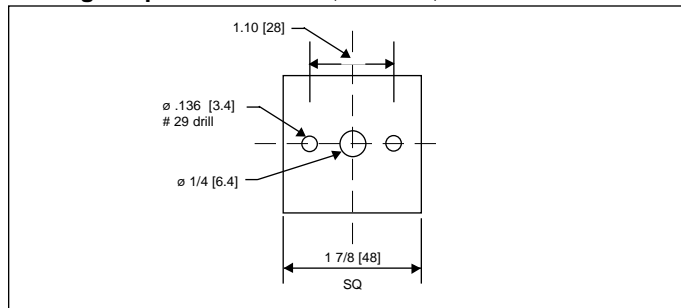

Dimensions

All ratings in brackets are metric.

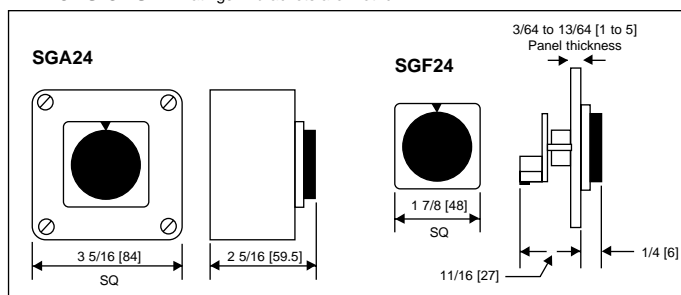

To convert a pulse width modulated signal to a 2 to 10 VDC signal for Belimo proportional actuators. (Series 3)

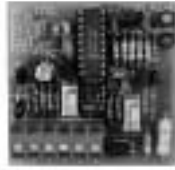

Wiring diagram

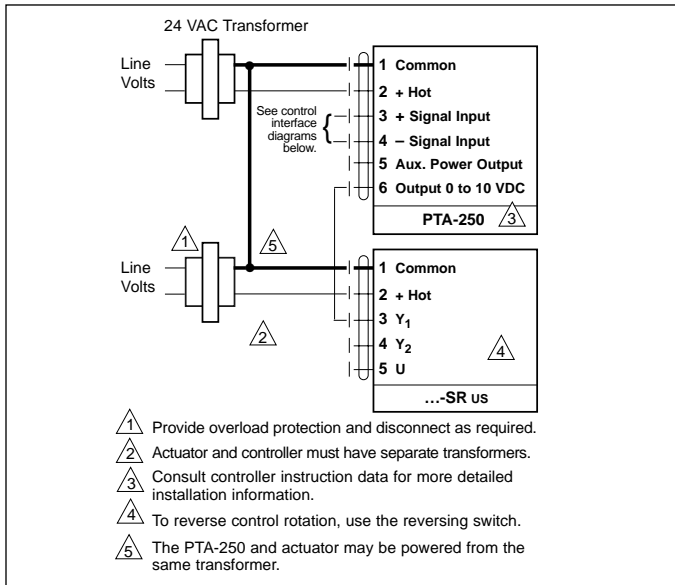

- 1 Provide overload protection and disconnect as required.
- 2 Actuator and controller must have separate transformers.
- 3 Consult controller instruction data for more detailed installation information.
- 4 To reverse control rotation, use the reversing switch.
- 5 The PTA-250 and actuator may be powered from the same transformer.

Technical Data PTA-250

Power supply	24 VAC ±15%
	24 VDC ±15%
Power consumption	<1 W
Transformer sizing	2 VA
Input isolation:	optically isolated (when wired as such)
type:	normal or triac, jumper selectable
trigger level:	12 to 24 VAC/VDC or dry contact to com
time between trigger pulses:	12.5 milliseconds min
impedance:	VAC - 500 Ω, VDC - 10 KΩ
pulse duration/resolution:	four selectable ranges, in seconds of dry contact or SSR closure ± 40% of signal increment
Range 1:	0.0235 to 6 seconds/in 0.0235 sec increments
Range 2:	0.0196 to 5 seconds/in 0.0196 sec increments
Range 3:	0.1 to 25.5 seconds/in 0.100 sec increments
Range 4:	0.59 to 2.93 seconds/in in 0.0092 increments
Output - voltage:	2 to 10 VDC
- current:	15 mA max
- accuracy:	± 2%
Electrical connection	wire terminals, 14 gauge max
Ambient temperature	-20°F to +150° F [-30°C to +65° C]
Operating humidity	5% to 95% non-condensing
Mounting	Snap-Track (provided)
Dimensions - board:	2 3/16" x 2 3/16" x 9/16"
- with Track:	2 3/8" x 2 1/4" x 15/16"
Weight	1.5 oz

Application

The PTA-250 converts a single pulse-width modulated input to an analog, 2 to 10 VDC, output to modulate a Belimo -SR actuator. The PTA-250 is available for replacement of existing installations. The ...MFT product can replace 100% of the PTA-250 applications, more effectively.

Operation

A timed contact or solid state closure from the controlling microprocessor controller is converted to a linear analog output with 256 steps of resolution. The last output is held until the PTA-250 receives the end of the next pulsed output. The PTA-250's output will not wrap around if an excessively long input pulse is received. Four input pulse clock rates are jumper selectable. Normal/Triac input positions are also jumper selectable. The input signal can be optically isolated from the PTA-250 circuit and can accept either positive or negative polarity. A red LED indicator is provided to indicate that power is applied to the PTA-250 and that the microprocessor is functioning. A green LED indicator is provided to indicate the presence of a pulse from the controller.

Note: The onboard zero and span adjustments are not for field use.

Pulse timing selection

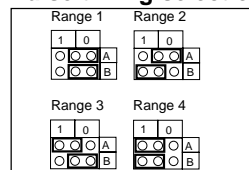

Normal/Triac input selection

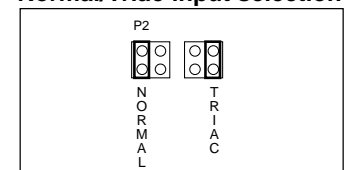

Control interface drawings

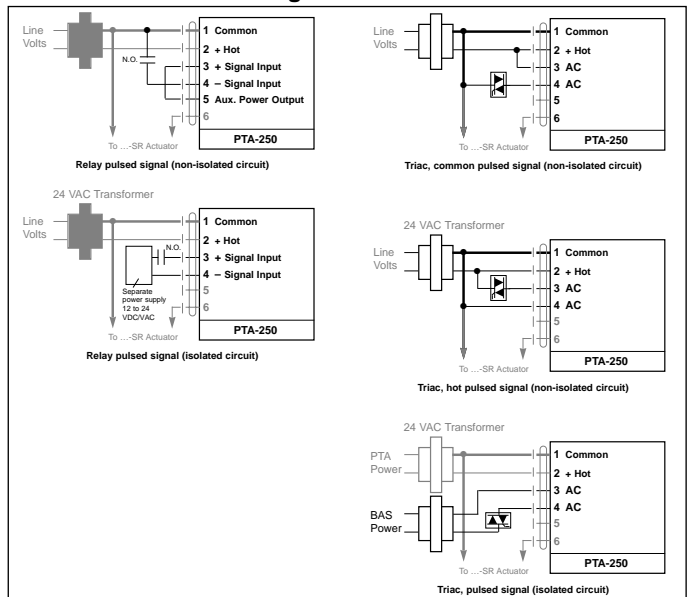

Dimensions

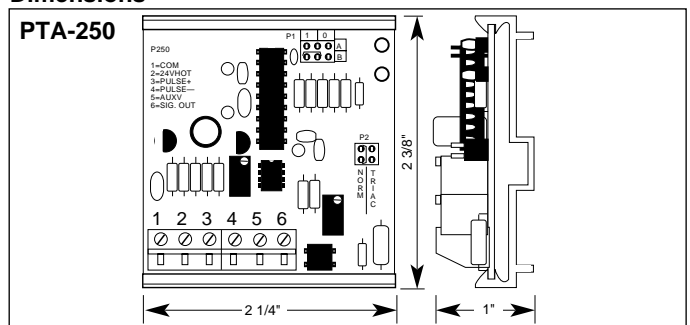

IRM-100 Input Rescaling Module



To adjust the zero start point and working span of Belimo proportional (. . -SR) actuators.
(Series 3)



Wiring diagram

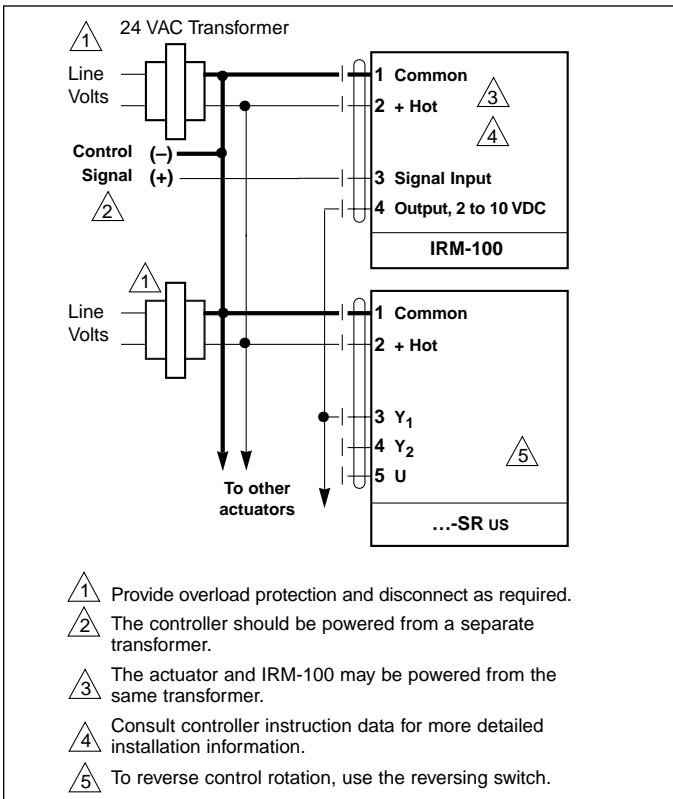

Technical Data		IRM-100
Power supply	supply voltage:	24 VAC ± 15% 24 VDC ± 15%
Power consumption		< 1 watt
Transformer sizing		1 VA
Input	voltage:	max voltage: 25 VDC zero (starting point): 0 to 18 VDC span adjustment: 2.6 to 17 VDC impedance: 400 KΩ
	current:	0 to 20 mA impedance: 500 Ω
	Output	voltage: 2 to 10 VDC current: 15 mA max
	Electrical connection	wire terminals, 14 gauge max
Ambient temperature		-20° F to +150° F [-30° C to +65° C]
Humidity		5 to 95% RH non-condensing
Mounting		Snap-Track (provided)
Dimensions	board:	1 3/16" x 2 3/16" x 9/16"
	w/Snap-Track:	1 7/8" x 2 3/8" x 15/16"
Weight		.9 oz.

Application

The IRM-100 input rescaling module is designed to change non-standard voltage or current signal levels into a 2 to 10 VDC output to modulate Belimo -SR type actuators. The IRM-100 is available for replacement of existing installations. The ...MFT product can replace 100% of the IRM-100 applications, more effectively.

Operation

The IRM-100 is installed between a controller and a Belimo ...-SR actuator. The module can be adjusted to work with a zero offset of 0 to 18 VDC and a span range of 2.6 to 17 VDC. The IRM-100 has a 2 pin jumper mounted to the circuit board. When the jumper is connected between these 2 pins, a 4 to 20 mA signal can be fed directly into the IRM. The result being the conversion of a wide range of analog control signals to a 2 to 10 VDC range.

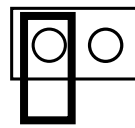

Jumper not connected to both pins for voltage applications (as shipped)



Jumper on both pins for 4 to 20 mA applications

The IRM-100 may also be used to sequence several actuators from one signal source. This is done by adjusting the IRM units to work at different input ranges. (Example: 2 to 5 VDC, 5 to 8 VDC, 8 to 11 VDC, etc.)

Calibration

1. Attach a variable signal source to the input and power wires to the IRM-100.
2. Apply power.
3. Input the minimum signal level.
4. Adjust the offset potentiometer to produce a 2 VDC signal at the output. A clockwise rotation of the potentiometer screw will increase the output signal.
5. Input the maximum signal level.
6. Adjust the span adjustment to produce a 10 VDC signal at the output. A clockwise rotation of the potentiometer screw will increase the output signal.
7. Double check the input-output calibration and install.

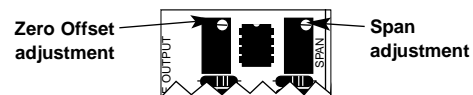

Dimensions

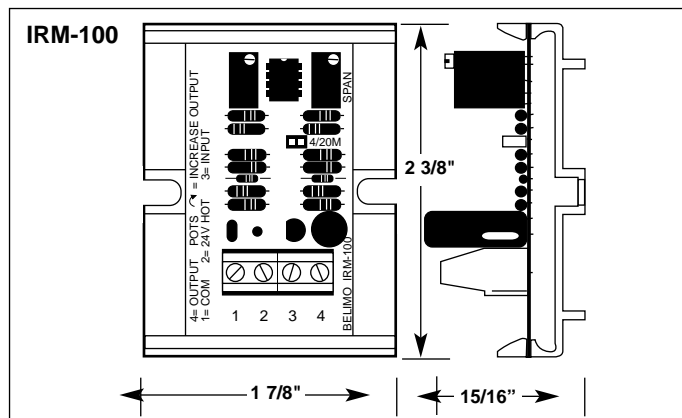

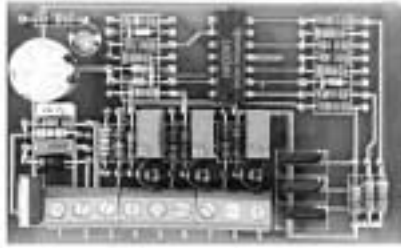

Wiring diagram

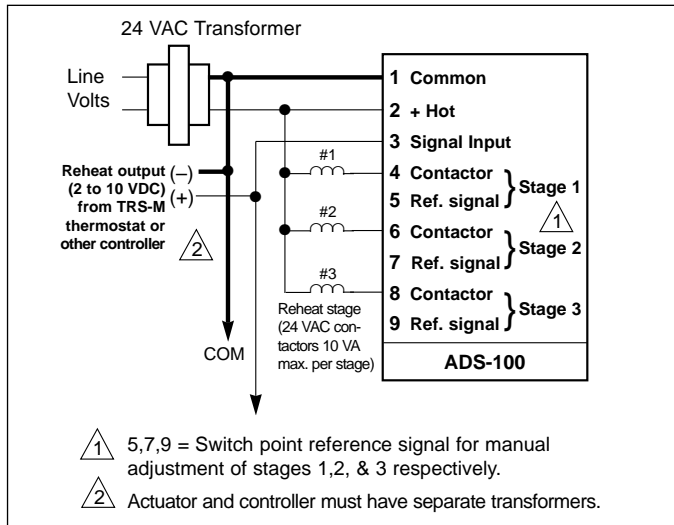

Switchpoint adjustment drawings

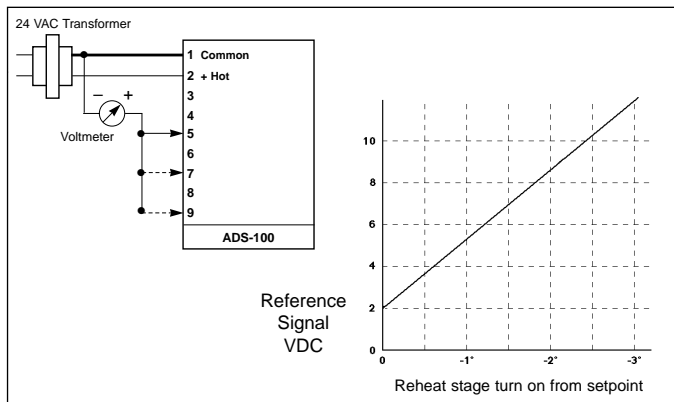

Technical Data	ADS-100
Power supply	24 VAC \pm 20% 50/60 HZ
Power consumption	1.5 W
Transformer sizing	3 VA (not including contactors)
Electrical connection	9 pole wire-terminal
Control input	2 to 10 VDC
Input impedance	100 K Ω
Adjusting range	2.5 to 9.5 VDC
Dead band	.3°F fixed
Switching capacity	24 VAC 10 VA max. (voltage sinking triac)
Mounting	Snap-Track (provided)
Dimensions	3 1/4" x 2" (3 7/16" x 2" w/snap-track)

Application

To control reheat coils and/or a fan stage in a fan-powered terminal unit. The ADS-100 is controlled by a 2 to 10 VDC reheat output of a temperature controller. (TRS-M)

Operation

The ADS-100 is designed to switch up to three independent stages of reheat on and off, according to a 2 to 10 VDC signal. The three output stages are furnished with a triac output. Each stage can be adjusted independently from each other over the 0 to 2.4° F throttling range of the TRS-M temperature controller.

The ADS-100 is shipped pre-adjusted, as shown in the following table. (Based on differential from setpoint)

	1st. stage	2nd. stage	3rd. stage
Switch ON	-0.45°F	-1.35°F	-2.25°F
Switch OFF	-0.15°F	-1.05°F	-1.95°F
Switch ON	2.8V	5.8V	8.8V
Switch OFF	0.4V	0.2V	0.4V

If desired, each stage may be field readjusted for special requirements. Three red LED indicators are provided to verify when the stages are energized.

Setpoint readjustment

Tools required: small screwdriver, voltmeter.

To readjust the output stages, the following procedure is used: Connect the voltmeter to the desired switchpoint reference signal output and terminal 1 (COM). Readjust the switchpoint reference signal output with the corresponding potentiometer to your desired switch point.

The adjustment range is 2.5 to 9.5 VDC. If you go below or above these values the ADS-100 may not switch off or on properly.

If this occurs you have to increase or decrease your switching level until the ADS-100 works correctly.

Dimensions

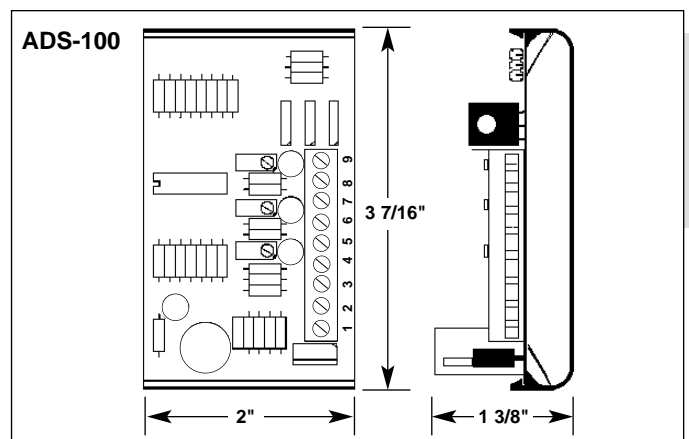



Wiring diagram

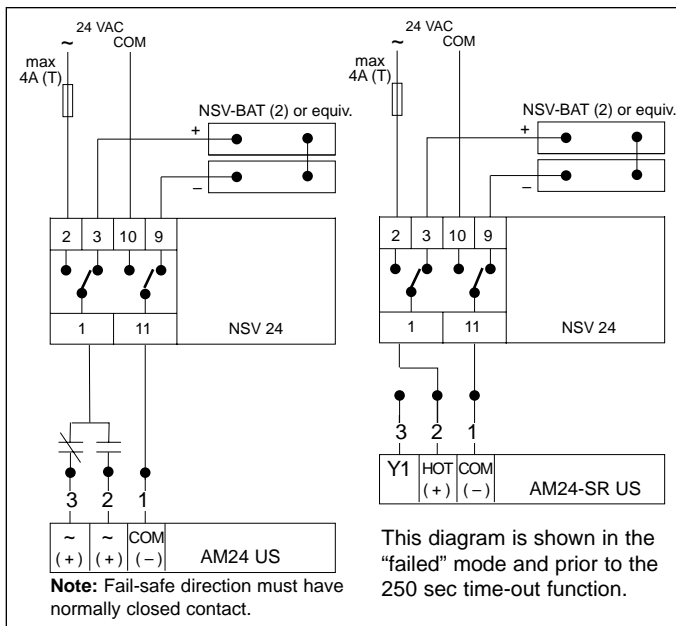

Technical Data	NSV24
Power supply	24 VAC \pm 20% 50/60 Hz
Fusing	4A slow blow fuse
Power consumption	Min. 5W (without actuator load)
Transformer	8 VA
Batteries	24 V Nominal 1.2 Ah (2-12 volt lead-acid batteries; batteries not supplied with module)
Maintenance	The batteries should be checked annually (approximate life is 6 years)
Charging circuit	Charge current max. 150 mA Charge voltage 24-27 V, temperature compensated
Battery back-up operation	24 V nominal 1.2 Ah, max. 60 W auto shut off after 250 seconds
Indication LED	Green - Main power source operation (battery will be charged) Red - Battery back-up operation
Mounting	Mounted in the control panel with an 11 terminal plug-in base (not supplied with module)
Ambient temperature	14°F to +122°F [-10°C . . . +50°C]

Application

Several Belimo damper actuators can be used either with 24 VAC or 24 VDC.

In case of a power failure, the NSV24 battery back-up unit switches the damper actuator from its main AC power supply over to the 24 VDC battery to drive the actuators to their safety position.

For easy maintenance, the battery back-up system is placed in the control panel, not in the actuator.

Several actuators may be powered by one back-up module. The batteries are separate from the NSV24.

Operation

The NSV24 is connected to the same 24 VAC power source as the damper actuators. It also charges the 24 V (2-12 volt batteries) storage battery. Its charge current is limited to 150 mA maximum, and the maximum charge voltage is temperature compensated. In case of a power failure, the NSV24 switches immediately over to the battery power source, and according to the control function, the actuators will move to their safety position. After 250 seconds, the batteries are disconnected from the actuators to prolong battery life. Because of this, a safe battery back-up can be provided for several short-term failures. The main power source operation is indicated by a green LED, and the battery power source by a red LED.

Connectable Actuators

Model	Maximum per module
GM24 US	20
GM24-MFT US	15
GM24-SR US	15
AM24 US	30
AM24-MFT US	30
AM24-SR US	30
NM24 US	30
NM24-MFT US	30
NM24-SR US	30
LM24-3 US	30
LM24-MFT US	30
LM24-SR-2.0 US	30

Accessories

NSV-BAT 12 VDC 1.2 Ah battery (2 required)

Dimensions

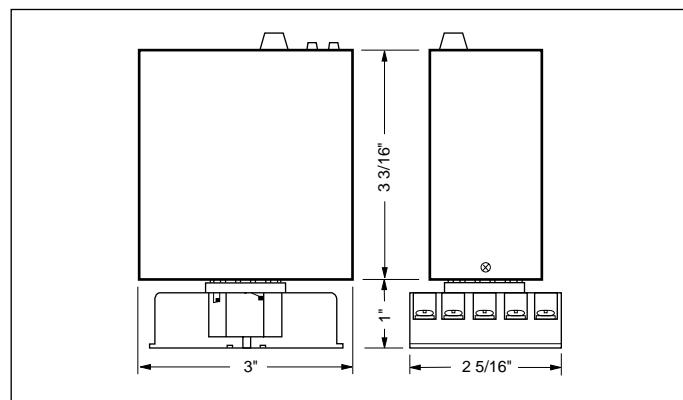



Technical Data	NSV-BAT
Battery type	Lead-acid
Voltage	12VDC
Nominal capacity	1.2 AH
Connections	.187 male spade
Weight	1.32 lb [.6 kg]

Application

The NSV-BAT battery is for use with the NSV24 battery back-up module. It is a sealed, maintenance free, lead-acid battery. Two NSV-BAT batteries are required for one NSV24.

Dimensions

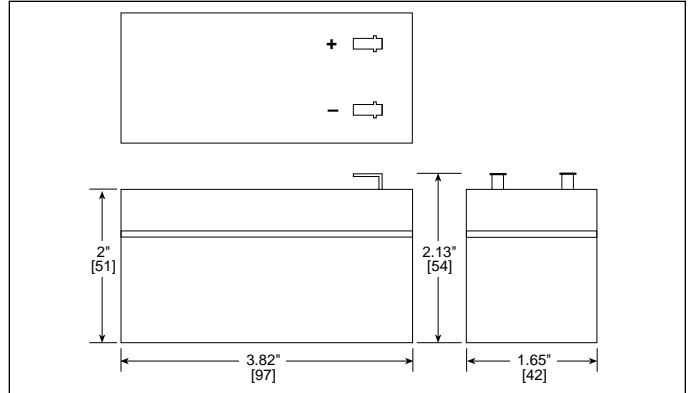

ZG-R01 Resistor for 4 to 20 mA conversions

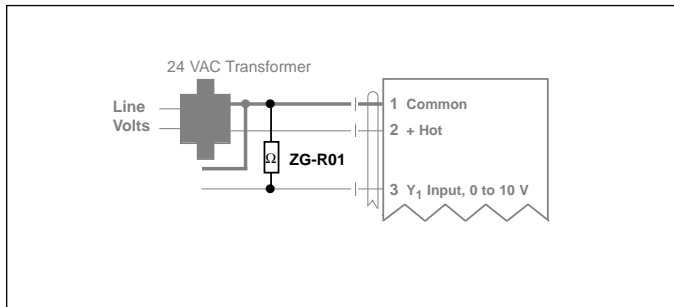

Application

The ZG-R01 is a 499 Ω Resistor which has been encased in a section of heat shrink tubing with short sections of hook up wire. The ZG-R01 is used to convert a 4 to 20mA signal into a 2 to 10 VDC control signal.

Dimensions

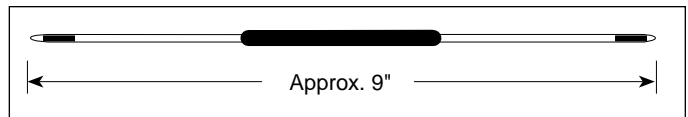

ZG-R02 50% voltage divider

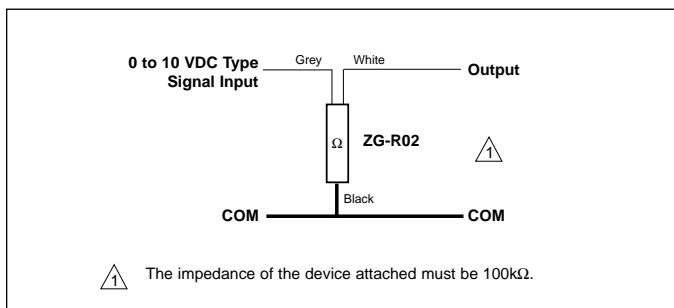

Application

The ZG-R02 is a voltage divider designed so that when connected to a 100 KΩ input impedance, the output signal is 50% if the input signal. The voltage divider circuit is encased in a short section of heat shrink tubing with three short sections of hook up wire.

Dimensions

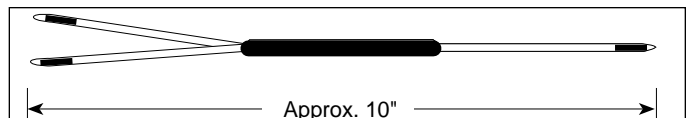

Resistor kits for multiple actuator applications

135 Ω Operation		4 to 20 mA Operation		For Honeywell® Electronic Series 90 Circuits (W7100, W973, T775)	
Number of Actuators	Resistance Ω	Number of Actuators	Resistance Ω	Number of Actuators	Resistance Ω
2	140	1	237	2	1300
3	71.5	2	150	3	910
4	47.5	3	124	4	768
5	37.5	4	113		
6	28	5	105		
		6	97.6		

Resistor Kit No. ZG-R03

Resistor Kit No. ZG-R05

Resistor Kit No. ZG-R06

Application

For use with the AF24-MFT95 US or SM24-SR94 US actuators and Honeywell® controllers

ZG-R03 - see table to left
 ZG-R05 - see table to left
 ZG-R06 - see table to left



ZG-CBNS US Junction box

Application

The ZG-CBNS US accessory is used when the application requires the wiring terminations to be made at the actuator.

Operation

The ZG-CBNS US serves as an electrical junction box. The products that can be used with this accessory are as follows:

NF24 US, NF24-S US,
 NF120 US NF120-S US
 NF24-SR US, NF24-MFT US

AF24 US, AFR24 US, AFR24-S US
 AF120 US, AFR120 US, AFR120-S US
 AF230 US
 AF24-SR US, AFR24-SR US. AF24-MFT US

Due to the internal volume of this junction box, according to UL requirements, The ZG-CBNS US **CANNOT** be used with the following products:

NF24-S2 US
 AF24-S US
 AF120-S US
 AF230-S US

Technical Data	ZG-CBNS US
Voltage rating	250 VAC
Electrical connection	Maximum 5 line voltage connection
Housing rating	UL94 5V
Material type	FR/ABS CYCOLAC KJW4051
Ambient temperature	-22°F to+122°F [-30°C to +50°C]
Storage temperature	-40°F to +176°F [-40°C to +80°C]
Agency listing	UL 873 (pending)
Quality standards	ISO 9001
Weight	<.5 lbs

Assembly and Installation

1. Remove supply voltage from the actuator and / or the auxiliary switch.
2. Remove the plastic insert from the actuator conduit fitting. (1)
3. Cut the actuator cable (s) to approximately 6 inches. Remove approximately 4 inches of the black cable insulation. Be sure not to damage the insulation of the conductors inside. This will void the actuators warranty.
4. Insert the actuator cable (s) into the junction box holes (A and B). Slide the housing towards the actuator.
5. Insert the cable (s) through strain relief assembly (3), thread strain relief assembly to the actuator conduit fitting (1) and tighten. Thread the nut (4) over the cable and tighten. Repeat process for the second cable. If no second cable is present, use the plug (5) with the nut (4). The second strain relief assembly is required to properly secure the housing to the actuator.
6. Assemble the cover and gasket: Knock out the appropriate conduit hole in the junction box cover (7). Pull field wiring through the hole in the cover and install the field supplied conduit fitting. Optional, knockouts are available at the sides of the junction box.
7. When wiring connections are completed, secure the box cover in place with the supplied screws (8).
8. Install the actuator.

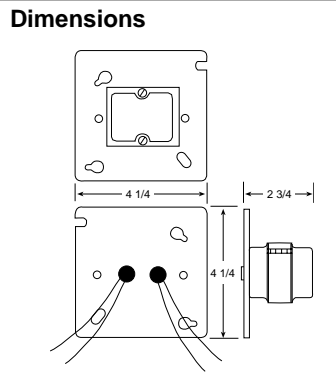
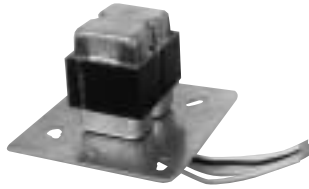

Wiring diagram

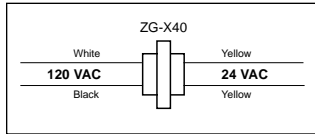

Technical Data	ZG-X40
Primary Voltage	120 VAC 50/60 Hz
Secondary Voltage	24 VAC
Max VA Rating	40 VA
Connections	6 1/2" leads with stripped ends
Type	Class 2
Mounting Method	4 1/4" square outlet box cover
Agency Approvals	UL 1585, CSA 22.2 #66

Application

The ZG-X40 is a 40 VA, 120 to 24 VAC transformer. It is designed so that both the primary and secondary leads exit through the same side of a 4 1/4" square outlet box cover. With this design, all wiring can be done inside a standard J-box with a minimum amount of labor.

Wire Specification

No. 18 AWG leads, 6 1/2" length	
Termination	Color
Primary	White-Black
Secondary	Yellow-Yellow

Maximum Number of Like Actuators per Transformer

Model #	Qty	Model #	Qty
NM24 US	11	GM24-SR US	5
NM24-SR US	13	AF24. . US	4
AM24 US	8	NF24 (-S) US	5
SM24-S US	3	NF 120 (-S) US	5
AM24-SR US	8	NF24-SR US	6
SM24-SR94 US	8	LF24 US	8
GM24 US	6	LF24-SR US	8

Refers to appropriate actuator documentation for specific VA ratings.

Power supply, signal simulator PS-100



Technical Data	PS-100
Power supply	120 VAC 50/60 Hz
Power consumption	< 4 W without actuator
Transformer	Primary: 120 VAC, 35 W Secondary: 24 VAC, Class 2 trans. PN: PS-XFMR
Terminal outputs	Push-button, wire terminals (12) On-off, Floating Point 135Ω, 0 to 10 VDC
Input	0 to 10 VDC
Display	LCD
Readouts, Output	0 to 10 VDC in volts or percentage based on a 2 to 10 VDC control span
Readouts, Input	0 to 10 VDC in volts or percentage based on a 2 to 10 VDC control span
Weight	3 lbs [1.4 kg] with case

Application

The PS-100 power supply and signal simulator is designed to operate most proportional, floating, and on-off style actuators without the presence of a controller.

The PS-100 can produce 24 VAC on-off and floating control signal along with a 0 to 10 VDC and 135Ω proportional signal. A multi-function digital display is provided which can read either the 0 to 10 VDC output or a 0 to 10 VDC feedback signal either as voltage or percentage of control.

The PS-100 comes with a 120 to 24 VAC, plug into the wall transformer for power. Both the PS-100 and transformer are supplied in a black fabric carrying case.

Replacement Power Supply: PS-XFMR

Dimensions

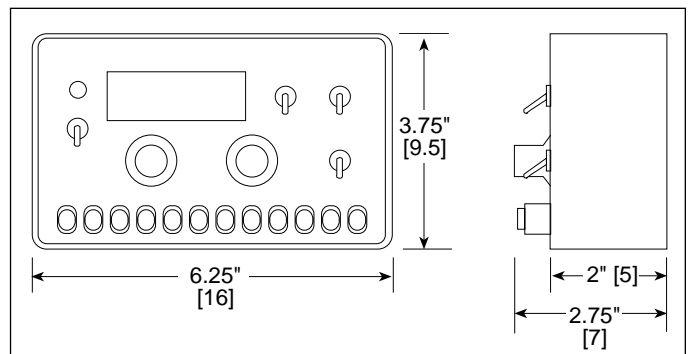

ZG-HTR NF/AF Thermostat/heater Kit



For NF/AF Series actuators

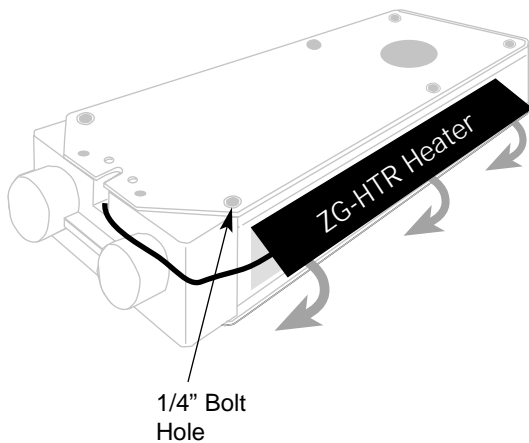
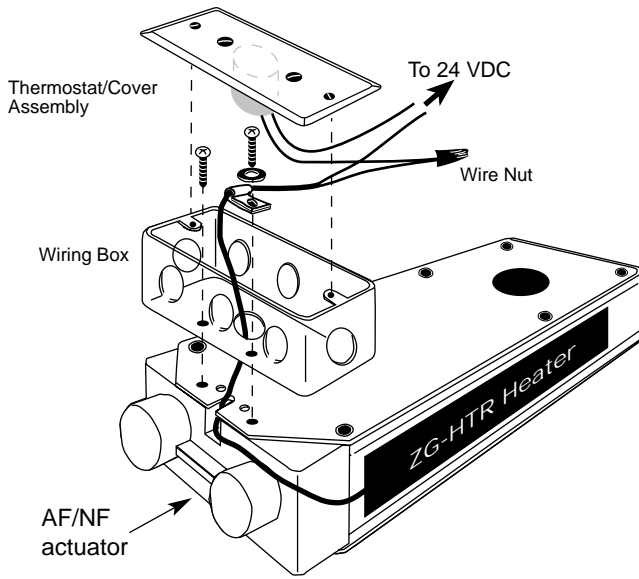

Application

The ZG-HTR Thermostat/Heater kit is designed to be field installed to the NF and AF series actuators. The ZG-HTR provides a thermostatically controlled heater which allows the NF/AF actuators to be used below their normal low ambient temperature rating. At approximately 10° F [-12° C] the heater energizes to maintain the actuators internal temperature to within working limits. The rubberized heating element has an adhesive back which attaches to the side of the actuator housing. The thermostat assembly mounts to the rear of the actuator and provides for the connection of the 24 VAC supply voltage. The actuator/heater assembly should be contained in a housing, similar to the ZS-100 Weather Shield, to achieve best results.

Instructions

1. Determine which side of the NF/AF actuator the heater element will be fastened to.
 2. Clean the mounting surface to remove any dust, oil film, etc. which may prevent the heater from attaching securely. A cleaning solvent which leaves no residue is recommended.
 3. Carefully peel back the clear plastic backing from the heater element. Care must be taken not to handle the adhesive back or have it make contact with any surface prior to mounting it to the actuator side.
 4. Without making contact between the actuator and heater, position the heater element so that the wire end is towards the rear of the actuator. The edge by the wire should line up with the center of the 1/4 bolt hole on the top of the actuator as indicated in the drawing at the left. Center the heater element so it is equally spaced from top to bottom on the actuator side.
- Warning:** Once the adhesive back makes contact with the actuator surface, it should **not** be removed.
5. Carefully make contact with the top side of the heater and gradually roll the heater element to make full contact with the actuator side.

Dimensions (All numbers in brackets are metric.)

Standard:

∅ 3/8" to 3/4"

□ 3/8" to 5/8"

Optional*

∅ 3/4" to 1.05"

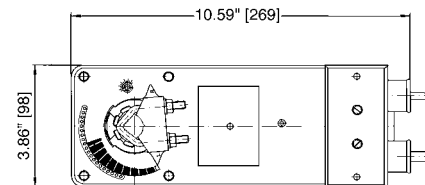
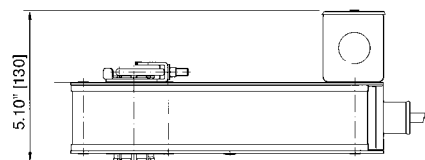

*with K4-1 US clamp

Technical Data	ZG-HTR
Power supply	24 VAC ± 20% 50/60 Hz
Transformer sizing	35 VA
Heater output	35 watts
Actuator low ambient rating	with enclosure: -40° F [-40° C] enclosure with 1" insulation: -58° F [-50° C]
Weight	11 oz [320 g]

6. If a conduit fitting is supplied with the actuator, on the side of the actuator which will have the wiring box, remove and discard the 2 screws which fasten the conduit fitting to the actuator.
7. Position the wiring box at the rear of the actuator. Mount the wiring box to the rear of the actuator using only the left screw, the one shown without a washer.

Note: If the conduit fitting is not provided on the model actuator being used, use the nuts provided to secure the wiring box to the actuator.

8. Feed the cable from the heater element through the slot at the rear of the actuator into the hole in the bottom of the wiring box.
9. Slip the cable through the wire clamp removing any slack in the wire from the heater to the fastening point in the wiring box. Fasten the clamp to the actuator using the remaining screw and washer.
10. Determine which conduit fitting hole in the wiring box will be used to provide the power source to the heater circuit.
11. Remove the desired knock-out in the wiring box and, if used, fasten the conduit fitting.
12. Install the actuator following the actuator installation instructions.
13. Fasten one of the red heater wires to one of the black thermostat wires using the wire nut supplied.
14. Connect 24 VAC power to the remaining wires.
15. Fasten the thermostat/cover assembly to the wiring box.

Wiring diagram

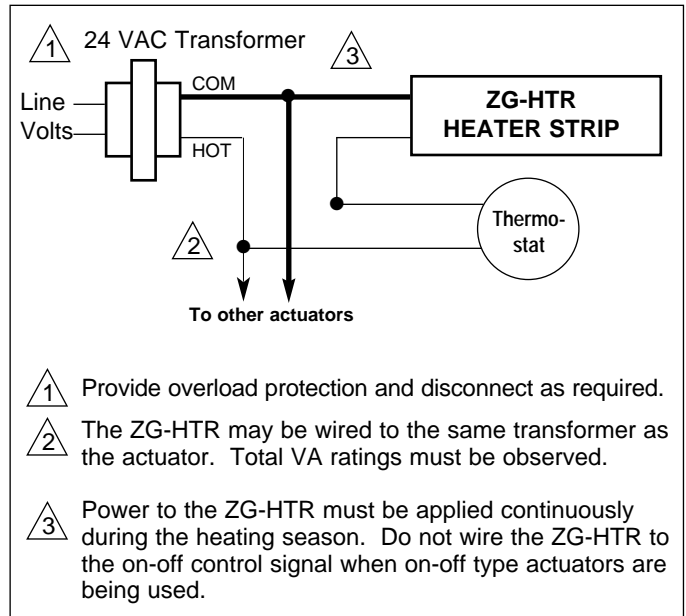

Special Control Range Applications

Control Signal	Belimo Actuator	Accessory	Notes
1 to 5 VDC	LM24-MFT US NM24-MFT US AM24-MFT US GM24-MFT US NF24-MFT US AF24-MFT US LF24-MFT US	None	Preset at factory or use MFT Handy device Set start point for 1 VDC, span for 4 VDC
4 to 20 mA	Any -MFT,-SR Actuator	ZG-R01, or 500Ω, 1/2 w resistor	Wire the ZG-R01 across the wires #1 and #3
10.5 to 13.5 VDC	LM24-MFT US NM24-MFT US AM24-MFT US AM24-MFT US GM24-MFT US NF24-MFT US AF24-MFT US LF24-MFT US	None	Preset at factory or use MFT Handy device Set start point for 10.5 VDC, span for 3 VDC
14 to 17 VDC	LM24-MFT US NM24-MFT US AM24-MFT US SM24-MFT US GM24-MFT US NF24-MFT US AF24-MFT US LF24-MFT US	None	Preset at factory or use MFT Handy device Set start point for 14 VDC, span for 3 VDC
Pulse Width Modulation	LM24-MFT US NM24-MFT US AF24-MFT US AM24-MFT US SM24-MFT US NF24-MFT US AF24-MFT US LF24-MFT US	None	Preset at factory or use MFT Handy device

*Preset at factory or use MFT Handy device

IRM-100 Calibrate the IRM-100 for an input range of 1 to 5 VDC. Calibrate IRM-100 2-10 in 2 to 10 out for signal amplification.

Sequencing Two or More Actuators With One Control Signal using the IRM-100

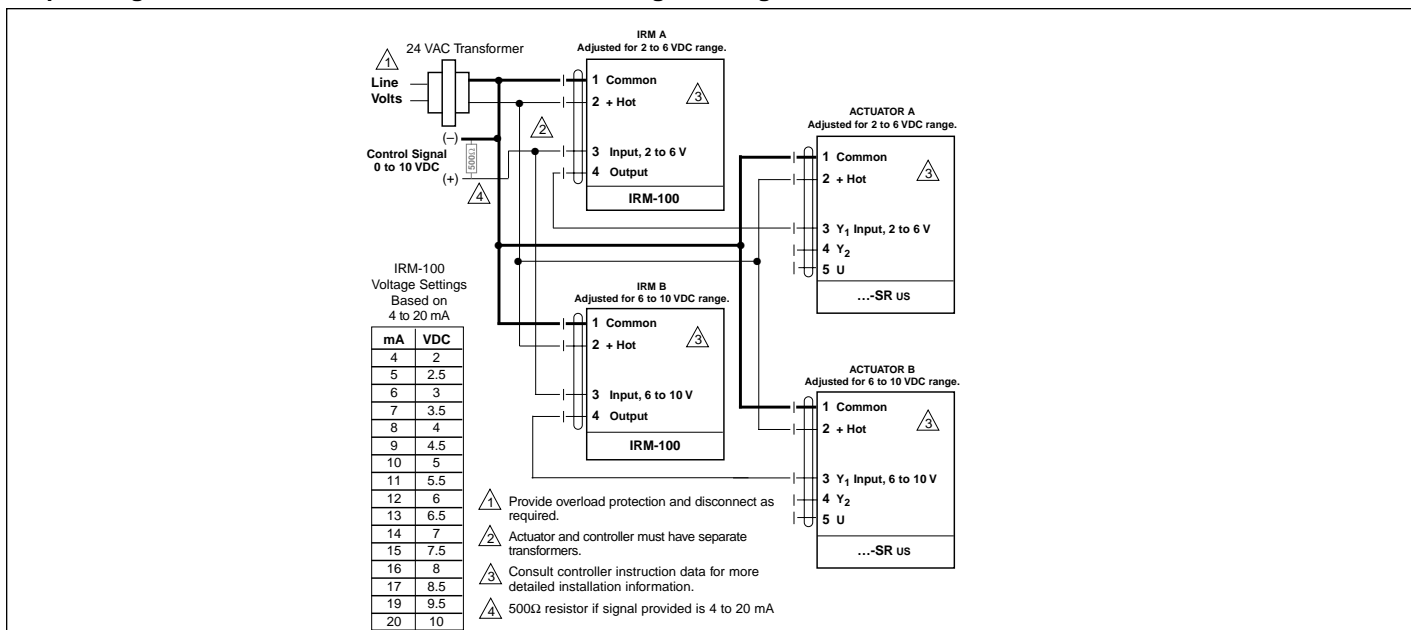

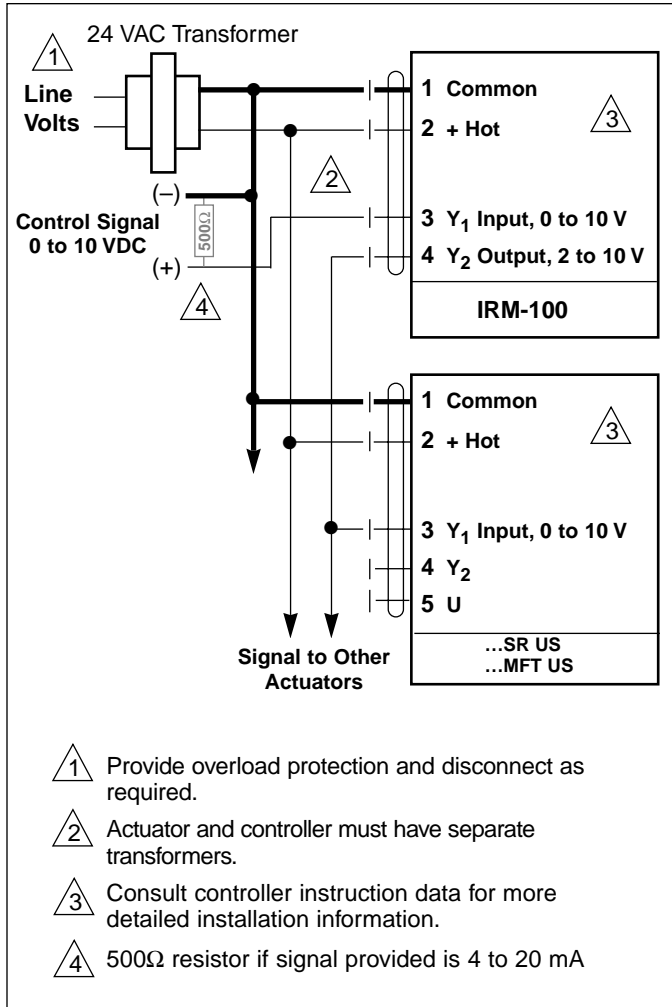

F20358 / 5 4 3 2 1 -01/04-10M-IG- Subject to change. © Belimo Aircontrols (USA), Inc.

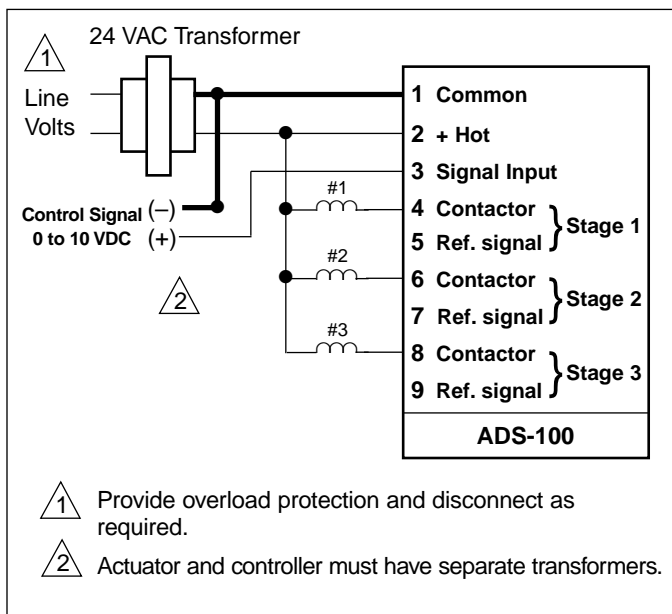

Electronic Accessories